

AVAILABLE APPROACHES FOR OVERCOMING LOW BIOAVAILABILITY OF RESVERATROL

Milos Z. Gostimirovic¹, Jovana N. Rajkovic¹, Aleksandar V. Petrovic², Jelena M. Cvejic³, Milica T. Atanackovic-Krstonosic³, Ljiljana C. Gojkovic-Bukarica^{1*}

¹Institute of Pharmacology, Clinical Pharmacology and Toxicology, Faculty of Medicine, University of Belgrade, 11000 Belgrade, Serbia, ²Faculty of Agriculture, University of Belgrade, 11080, Belgrade-Zemun, Serbia, ³Department of Pharmacy, Faculty of Medicine, University of Novi Sad, 21000 Novi Sad, Serbia

Over the years researchers have been trying different methods aiming to overcome RSVs low water solubility: co-administration with inhibitors of glucuronidation, use of RSVs methylated analogs and designing the new delivery systems - using cyclodextrins (found in lemon juice) or endogenous proteins with high binding capacity to RSV: **serum albumin, haemoglobin, fibrinogen or LDL cholesterol**.

PRODRUGS

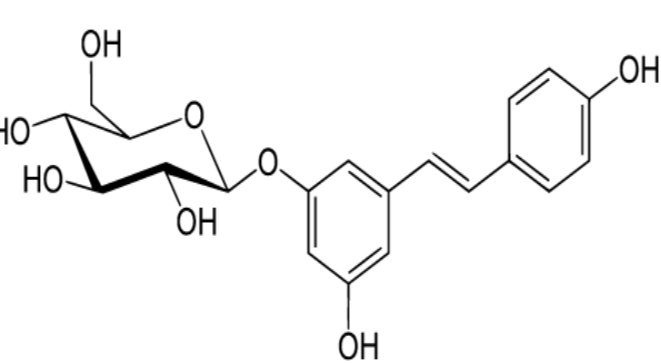
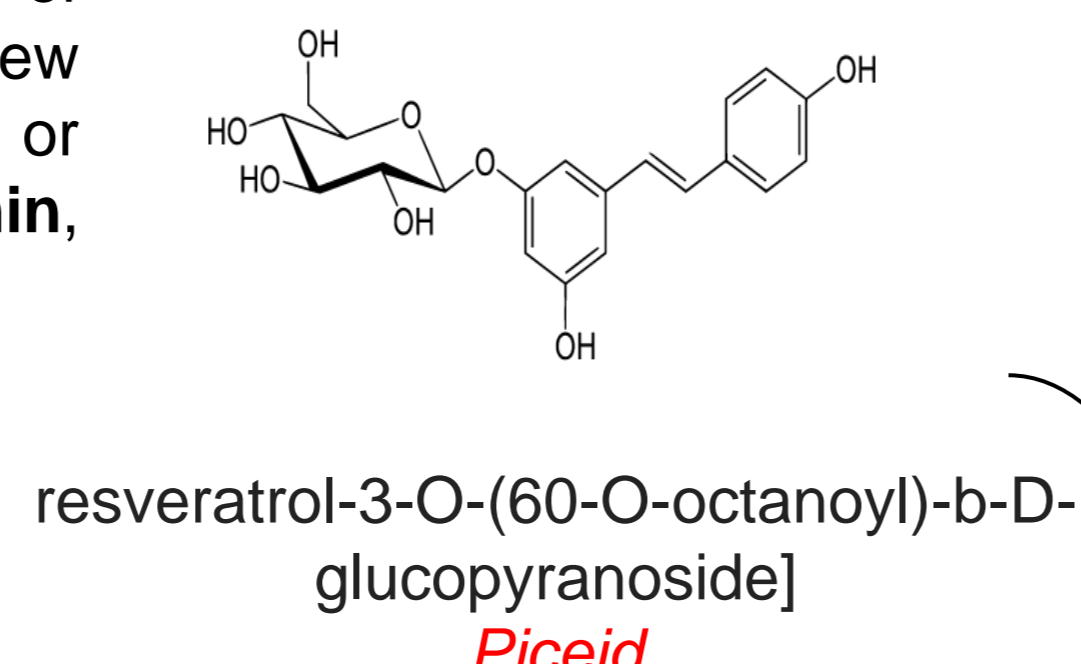

Improved treatment of neurodegeneration (Huntington's disease)

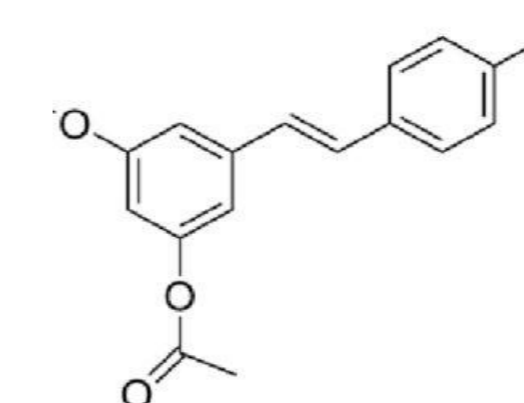

3,5,4'-tri-O-acetylresveratrol (TARES)

suppression of pulmonary inflammation and oxidative stress
increasing the concentration of free RSV

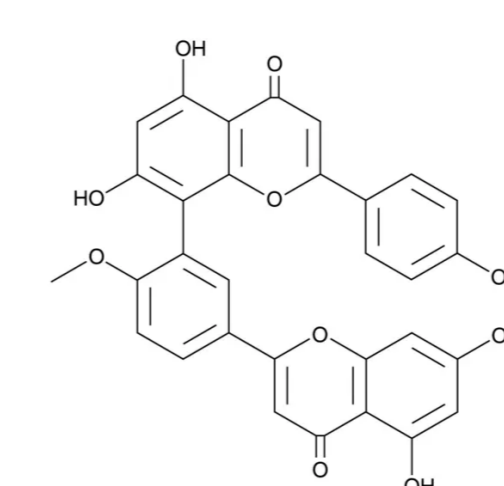

biflavone ginkgetin

SYNERGISM WITH OTHER PHYTOCHEMICAL

IMPROVING PHARMACOKINETICS

Formulations to improve its aqueous solubility

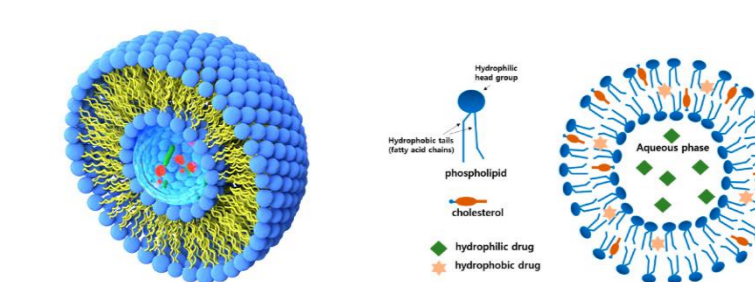

Liposomal RSV

Formulations to stabilize and protect

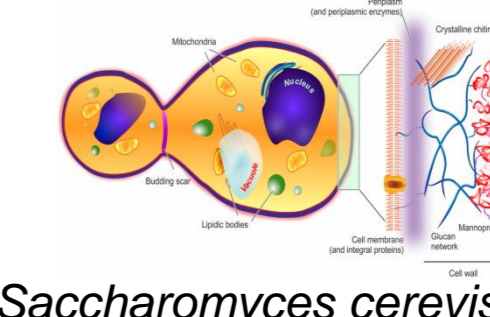

slower photodecomposition

Formulations to achieve targeted release

solubilize RSV most efficiently

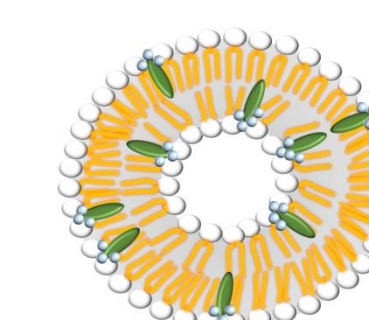

micellar solutions of bile acids

suppression of angiogenic properties of VEGF (vascular endothelial growth factor)
reduction of TNF- α and IL-6

INHALATION

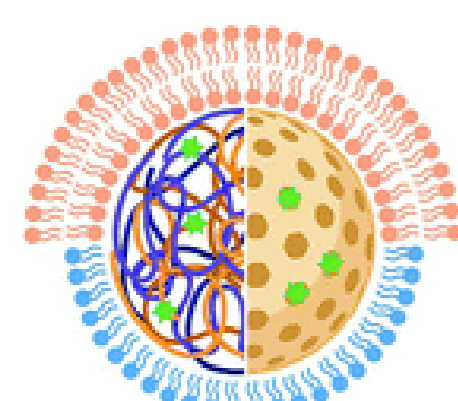

Dipalmitoylphosphatidylcholine-coated lipid nanoparticles (DPPC-LNs)

treatment of pulmonary arterial hypertension

TRANSDERMAL

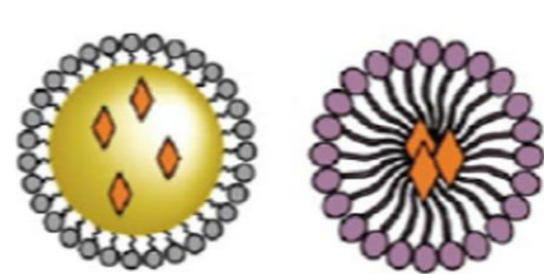

Microemulsions (Isopropyl myristate)

various skin conditions

ALTERNATIVE ROUTES OF ADMINISTRATION

BUCCAL

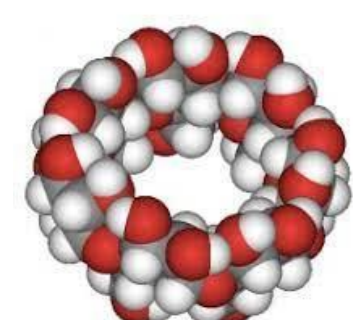

β -D-Cyclodextrin

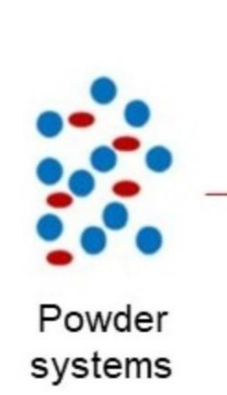

Powder systems

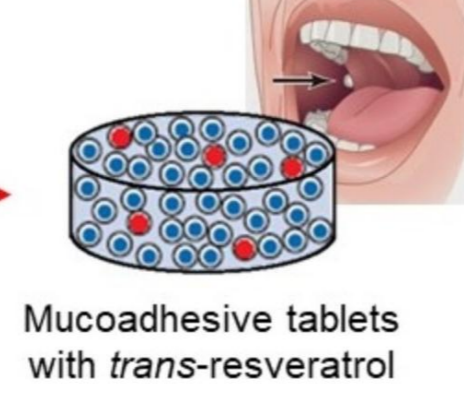

Mucoadhesive tablets with trans-resveratrol

Besides, many proteins used in the food industry may serve as RSV carriers:



β -lactoglobulin (a major whey protein)

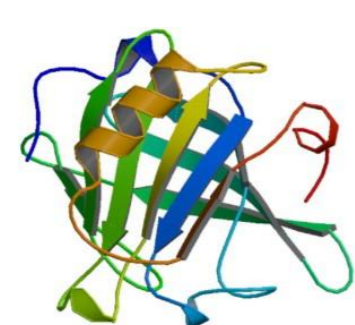

gliadin

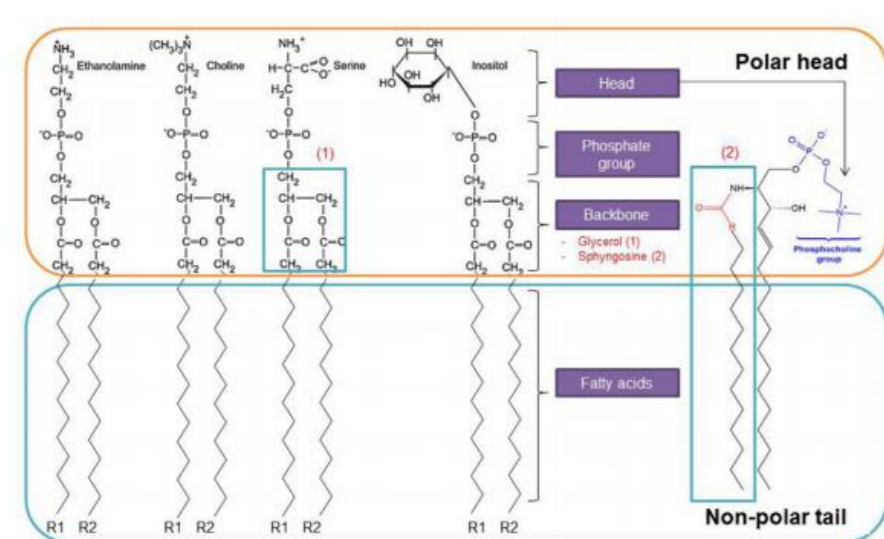

whole buttermilk

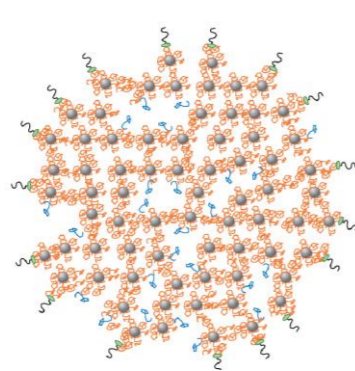

α -casein

In one study, liposomal RSV improved biochemical and histopathological alterations in doxorubicin-induced cardiomyopathy via upregulation of sarco/endoplasmic reticulum calcium ATPase2a expression. Ultra-flexible liposomes called transferosomes offer interesting delivery method that is suitable for transdermal application. Encapsulation of RSV using grape seed or orange oil, additionally, protects RSV against UV-light isomerization and degradation. It is very important to carefully monitor the dose of RSV since higher dose may cause adverse effects and lower dose may fail to exert any beneficial effect.

FUTURE PERSPECTIVES ?

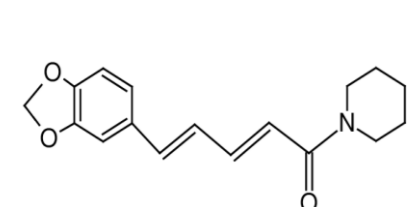

Piperine (Inhibitor of glucuronidation)

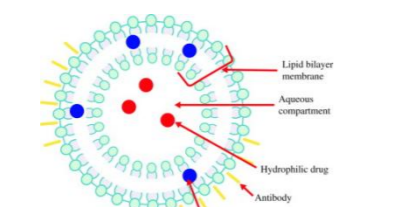

colloidal carriers in the nanometer range

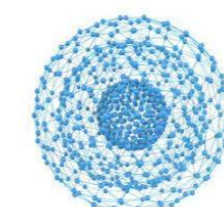

Biodegradable nanoparticles

METABOLITES

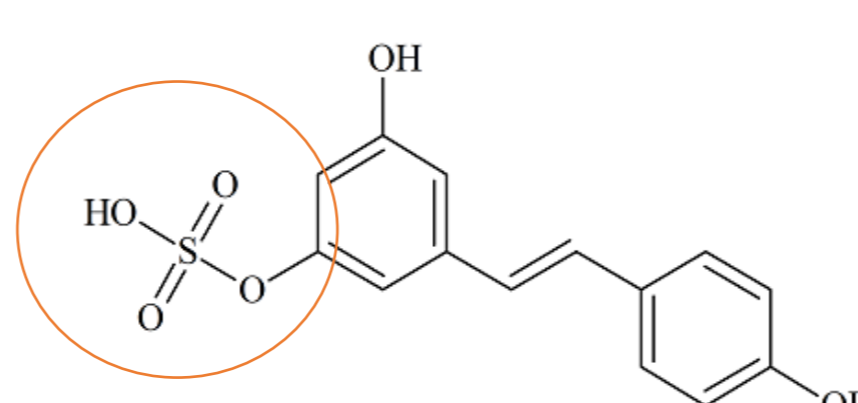

Resveratrol-3-O-sulfate

Better regulate gut microbial growth and provide superior gut barrier function

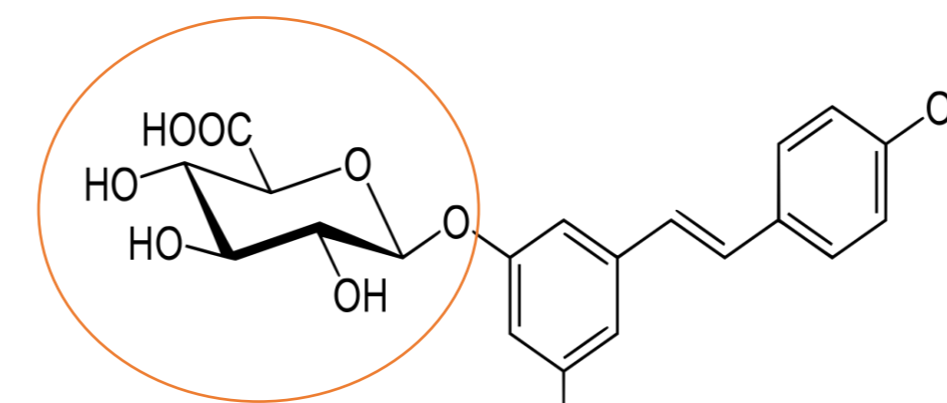

trans-Resveratrol-3-O-glucuronide

Very little activity although possesses estrogenic receptor α - antagonistic activity

NATURALLY OCCURRING RSV ANALOGUES

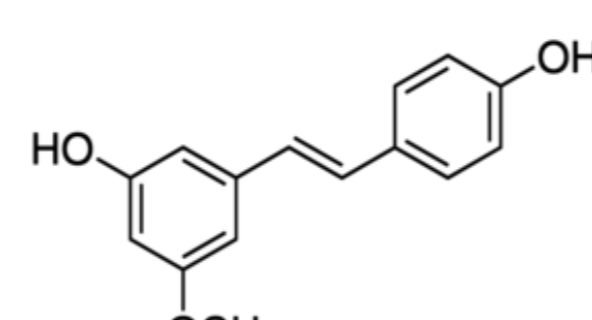

pinostilbene

Potent neuroprotective effects vs. RSV

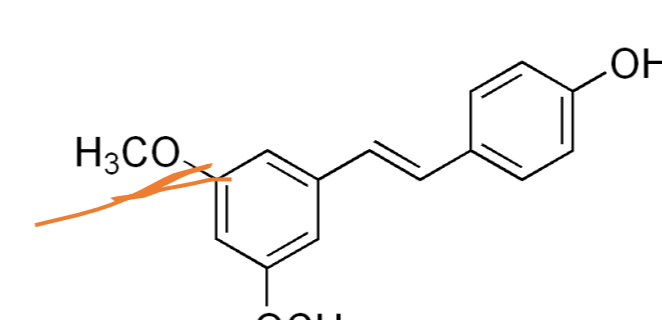

pterostilbene

Higher anti-inflammatory activity vs. RSV

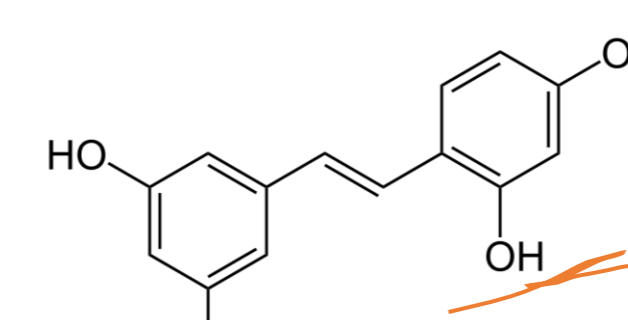

oxyresveratrol

Increase in anticancer bioactivity

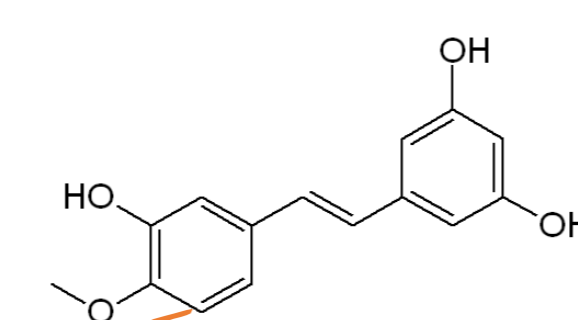

rhapontigenin

Increase in oral bioavailability

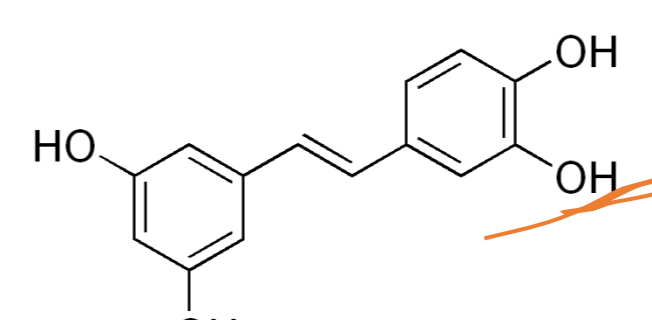

piceatannol

Increase in anticancer bioactivity

NANOTECHNOLOGY

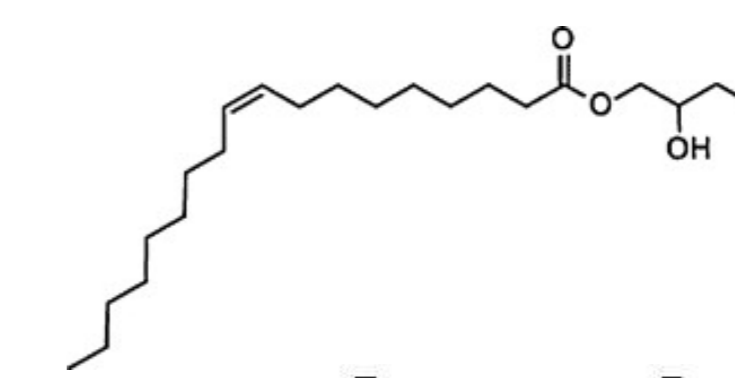

glyceryl monooleate liquid crystalline nanoparticles

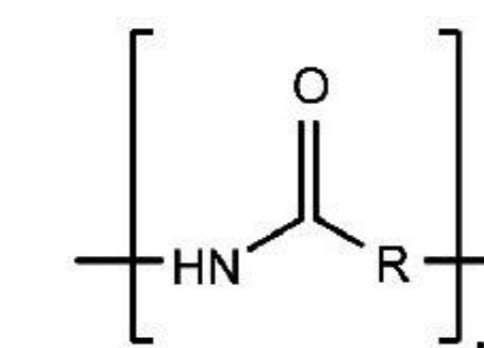

Zein nanoparticles

Nowadays nanotechnology-based RSV delivery systems which use various biocompatible materials, represent the most sophisticated method. Weather nutraceutical (biopolymer-based nanoparticles, emulsions) or parenteral (microbubbles, liposome) formulations, those delivery systems provide compelling alternatives for increasing RSV application potential and have the tenacity to evolve into widely applicable RSV carriers.

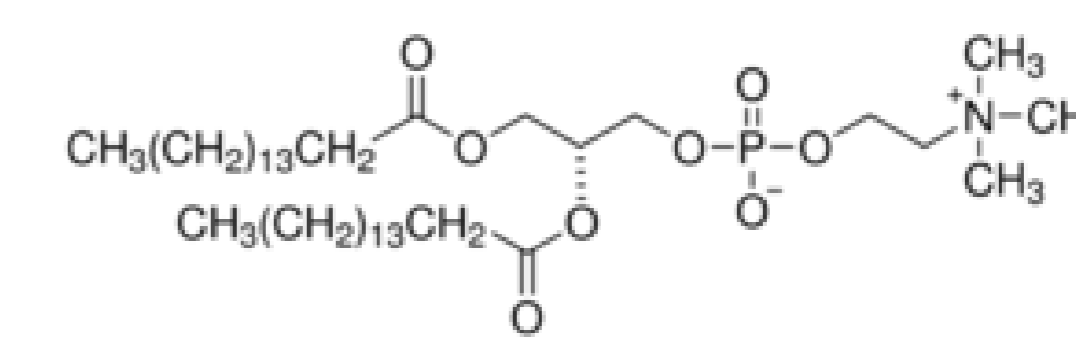

zwitterionic

(phosphatidyl-choline1, 2-dipalmitoyl-sn-glycero-3-phosphocholine)

Peanut oil, for example, is promising food-compatible way of RSV delivery but it seems that different liposomes: **zwitterionic** (made from saturated phosphatidyl-choline1, 2-dipalmitoyl-sn-glycero-3-phosphocholine and cholesterol) or **cationic** (made from soya lecithin, cholesterol and stearylamine) show precedence among other vehicles. RSV in cationic liposomes even have improved biological activity comparing to free RSV.

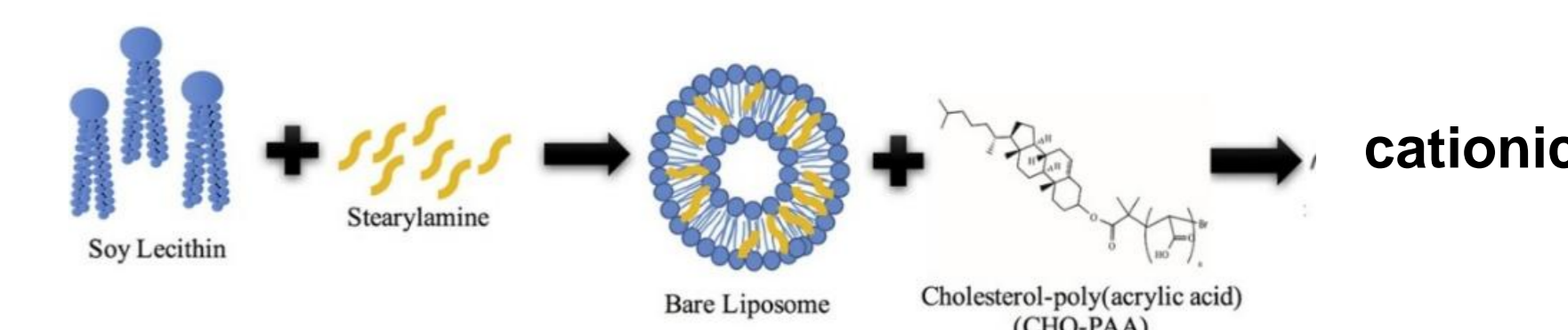

cationic